

Bonded T1

WHOLESALE TELEXEND

HIGHLIGHTS

Reliable—Fast, responsive bonded T1 for mission-critical uptime and performance

Expert Support—Specialized T1 service team available live 24 x 7 x 365

T1 Hotline—Dedicated T1 toll-free hotline for priority response

Industry-leading SLAs—Fast installation, repair, and 99.99% monthly uptime targets

Priority Routing—Includes site survey, basic inside wiring, and WAN router configuration

Professional Installation—Includes basic inside wiring and customer premises equipment (CPE) configuration

Deliver New Levels of Performance with MegaPath Bonded T1 Service

E-commerce. Corporate intranets. Web hosting. These are just some of the business basics driving the need for fast, mission critical Internet access. MegaPath Bonded T1 service allows you to tap into this rapidly expanding market while leveraging MegaPath’s comprehensive nationwide network to reach new customers.

BENEFITS OF BONDED T1. MegaPath TeleXtend bonded T1 service combines up to eight industry-standard DS1 loops bonded together using multi-link point-to-point protocol (MLPPP) or multi-link frame relay (MLFR) to deliver up to 12 Mbps of symmetrical speed in full T1 increments. The flexible approach MegaPath uses to bond T1 lines gives your customers a choice of 3.0, 4.5, 6.0, 7.5, 9.0, 10.5, and 12.0 Mbps of bandwidth that allows your customers to save on both monthly fees and equipment costs.

ENTERPRISE-CLASS SUPPORT. MegaPath has a specialized team of T1 experts who support you 24 x 7 x 365. A toll-free hotline dedicated to T1 partners helps ensure a fast response. And we dispatch repair technicians after hours, on weekends, and on federal holidays to keep your customers up and running.

SERVICE LEVEL AGREEMENTS. MegaPath provides industry-leading service level agreements (SLAs) that help ensure your customers get the uptime and performance they expect. Service credits are available for missed targets.

SLAS	TARGET METRIC
Service availability	99.99% monthly service availability
Time to restore service	4 hours mean time to repair (MTTR)
Network delivery	99.9% of data packets sent over Covad network
QoS Level 3 <i>Default for TeleXtend</i>	Regional network delay Layer 2: 10 milliseconds, Layer 3: 70 milliseconds
	National network delay Layer 2: 130 milliseconds
National network delay	130 milliseconds (Layer 2), 130 milliseconds (Layer 3)
Installation interval	2-4 TeleXtend bonded T1: 45 calendar days 5-8 TeleXtend bonded T1: 60 calendar days

QoS LEVEL	LATENCY (LAYER 2)	LATENCY (LAYER 3)
Level 4	10 ms round trip regional 120 ms round trip national	60 ms round trip
Level 5	10 ms round trip regional 110 ms round trip national	50 ms round trip

Bonded T1

WHOLESALE TELEXTEND

BONDED T1 IMPLEMENTATION

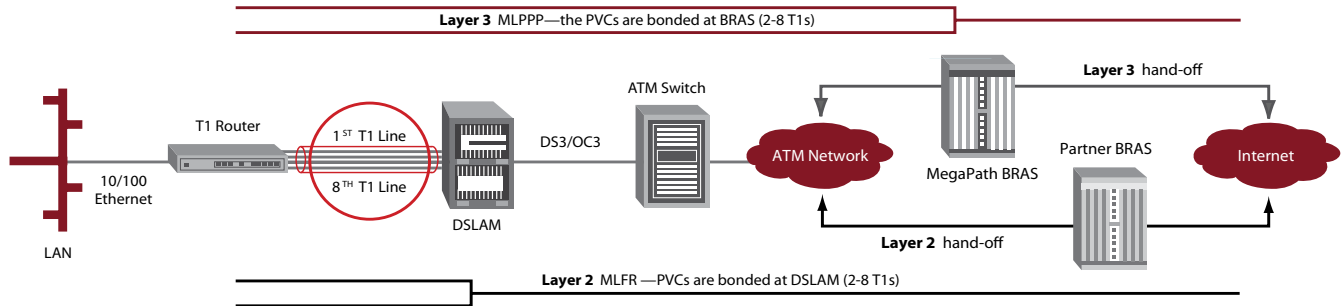

TECHNOLOGY	Up to eight industry-standard DS1 loops bonded using MLFR for Layer 2 and MLPPP for Layer 3 service.
SPEEDS	Up to 12.0 Mbps symmetrical speed in incremental T1 speeds (3.0 Mbps, 4.5 Mbps, 6.0 Mbps, 7.5 Mbps, 9.0 Mbps, 10.5 Mbps or 12.0 Mbps).
ARCHITECTURE	Private ATM network connected to IP network through 15 points of presence (POPs).
CUSTOMER PREMESES EQUIPMENT (CPES)	One-year warranty Layer 2 and 3—Bonded T1 3.0–6.0 Mbps: Samsung Ubigate iBG1000 router Layer 2 and 3—Bonded T1 3.0–9.0 Mbps: Samsung Ubigate iBG2016 router with 1 T1 WIC card Layer 2 and 3—Bonded T1 3.0–12.0 Mbps: Samsung Ubigate iBG2016 router with 2 T1 WIC cards
INSTALLATION	Professional installation by a MegaPath technician.
IP CONFIGURATION (LAYER 3 ONLY)	Network address translation (NAT) with one external IP address and 254 usable private IP addresses, or five fixed IP addresses; additional fixed IP addresses available for an additional fee. Available for Layer 3 only.
SUPPORT	Dedicated, advanced technical support team, structured for end-to-end problem resolution, available 24x7, even on weekends and holidays.
SLAs	Installation, service availability, repair time, and network performance are financially backed by service credits for missed targets.
TO ORDER	TeleXtend 3.0, 4.5, 6.0, 7.5, 9.0, 10.5, and 12.0 services are available as Layer 2 and Layer 3. Execution of a new MegaPath service module and fee module is required to order the services.

MEGAPATH SOLUTIONS. Value-added applications such as VoIP, video conferencing, and software as a service (SaaS) increase your revenue and help promote customer loyalty. More bandwidth makes these solutions possible but quality of service (QoS) optimizes the application performance to maximize your customer’s experience.

Contact your MegaPath account executive, email wholesale@megapath.com or call us at 408-856-6712.



W H O L E S A L E

2220 O’Toole Avenue San Jose, CA 95131-1326

© 2011 MegaPath. All rights reserved. MegaPath and the MegaPath logo are registered trademarks of MegaPath. Service is not available in all areas and is provided subject to MegaPath’s standard terms, conditions and policies.